

**Drop-In**  
**Drop-in refrigerated stainless steel**  
**surface (4 GN container capacity) with A**  
**overshelf**

ITEM # \_\_\_\_\_

MODEL # \_\_\_\_\_

NAME # \_\_\_\_\_

SIS # \_\_\_\_\_

AIA # \_\_\_\_\_

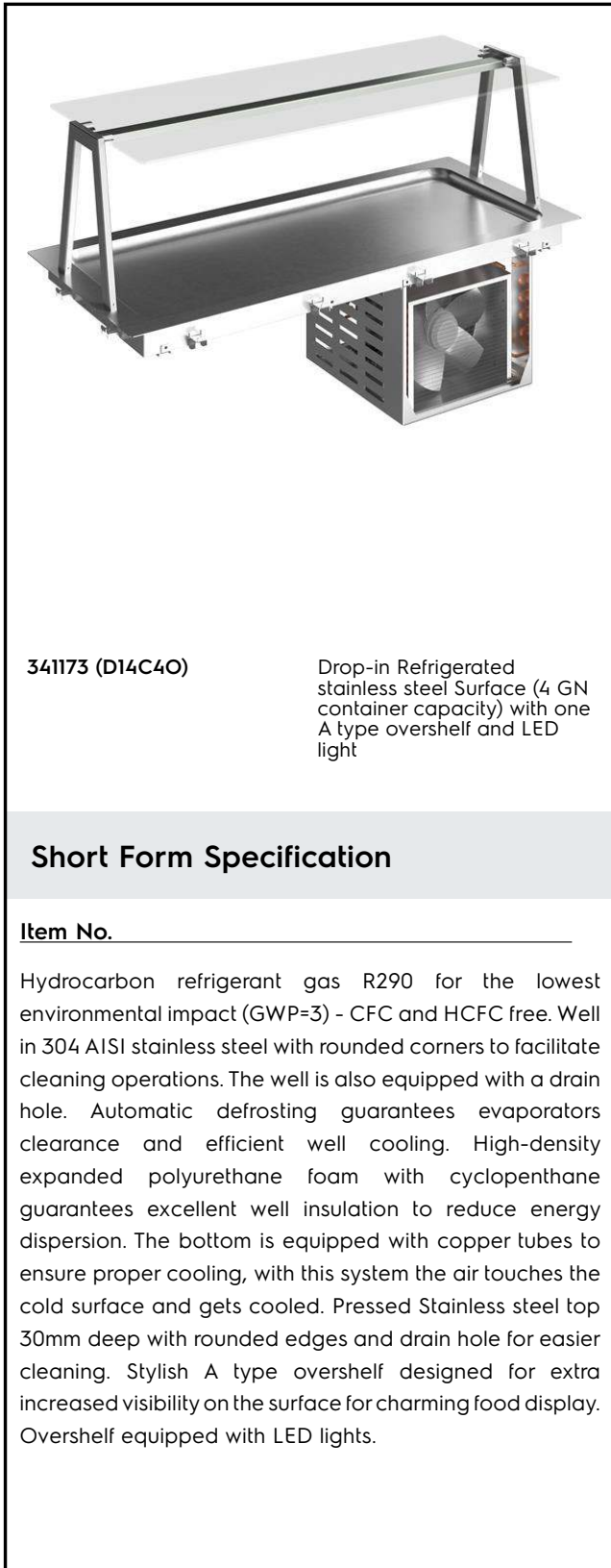
**341173 (D14C40)**

Drop-in Refrigerated stainless steel Surface (4 GN container capacity) with one A type overshelf and LED light

### Short Form Specification

**Item No.** \_\_\_\_\_

Hydrocarbon refrigerant gas R290 for the lowest environmental impact (GWP=3) - CFC and HCFC free. Well in 304 AISI stainless steel with rounded corners to facilitate cleaning operations. The well is also equipped with a drain hole. Automatic defrosting guarantees evaporators clearance and efficient well cooling. High-density expanded polyurethane foam with cyclopentane guarantees excellent well insulation to reduce energy dispersion. The bottom is equipped with copper tubes to ensure proper cooling, with this system the air touches the cold surface and gets cooled. Pressed Stainless steel top 30mm deep with rounded edges and drain hole for easier cleaning. Stylish A type overshelf designed for extra increased visibility on the surface for charming food display. Overshelf equipped with LED lights.

### Main Features

- CB and CE certified by a third party notified body.
- Precise temperature control and setting at 0,1°C .
- As standard the product comes with digitally controlled thermostat which is in line of HACCP norms and provides visual alarm as a warning of the increasing or decreasing temperatures.
- Food introduced at the correct temperature maintains its core temperature according to Afnor Standards.
- Automatic defrosting guarantees evaporators clearance and efficient well cooling.
- Designed to serve the food on plates .
- Equipped with a drain hole to easily discharge top condensation.
- Stylish A type overshelf designed for extra increased visibility on the surface for charming food display.
- Overshelf equipped with LED lights.
- Designed to be positioned in flush installation providing improved cleanability and suitable for modern design installations.

### Construction

- Well bottom is inclined to facilitate water drainage.
- Well in 304 AISI stainless steel with rounded corners to facilitate cleaning operations. The well is also equipped with a drain hole.
- Electronic control with temperature display.
- IPx2 water protection.
- The bottom is equipped with copper tubes to ensure proper cooling, with this system the air touches the cold surface and gets cooled.
- Pressed Stainless steel top 30mm deep with rounded edges and drain hole for easier cleaning.
- Overshelf in complete AISI 304.

### Sustainability



- Hydrocarbon refrigerant gas R290 for the lowest environmental impact (GWP=3) - CFC and HCFC free.
- High-density expanded polyurethane

**APPROVAL:** \_\_\_\_\_

foam with cyclopentane guarantees excellent well insulation to reduce energy dispersion.

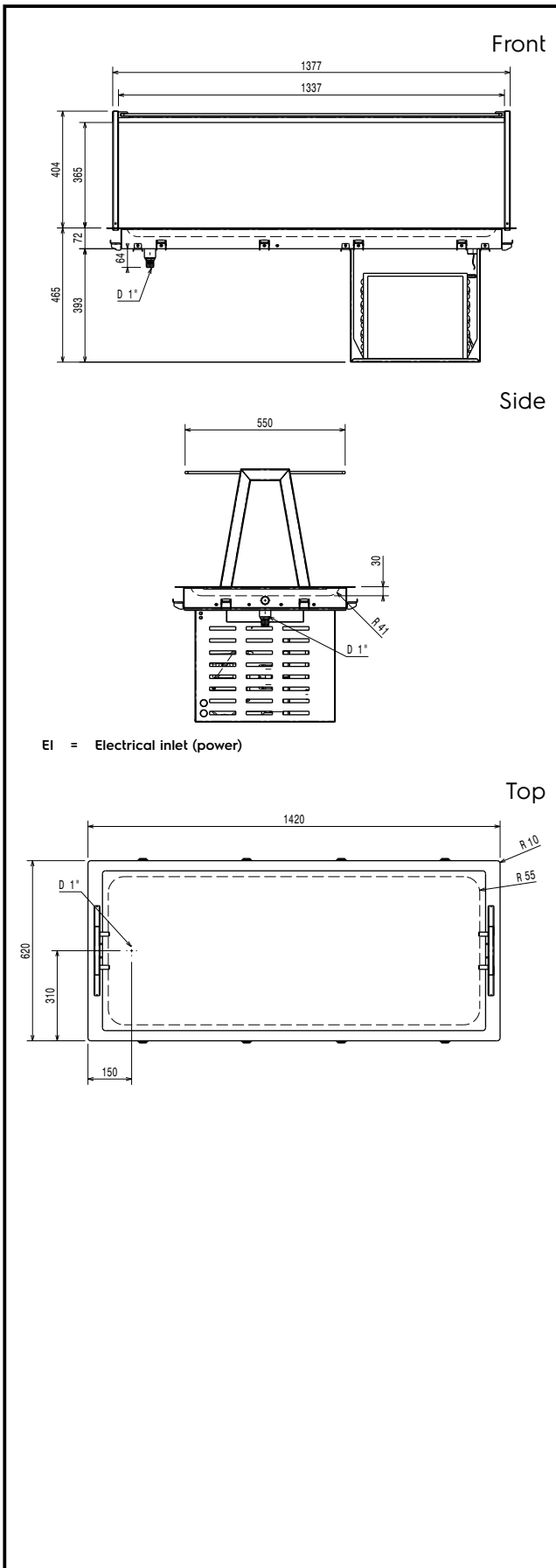

### Electric

#### Supply voltage:

341173 (D14C40) 220-240 V/1N ph/50 Hz

#### Electrical power max.:

0.6 kW

### Water:

#### Water drain outlet size:

### Key Information:

External dimensions, Width: 1420 mm

External dimensions, Depth: 620 mm

External dimensions, Height: 794 mm

Net weight: 67.6 kg

Shipping weight: 106 kg

Shipping height: 1080 mm

Shipping width: 680 mm

Shipping depth: 1460 mm

Shipping volume: 1.07 m<sup>3</sup>

Set temperature: -10 / 0 °C

Top temperature: -10 / 0 °C

### Refrigeration Data

Refrigerant type: R290

### Sustainability

Noise level: 58,8 dBA

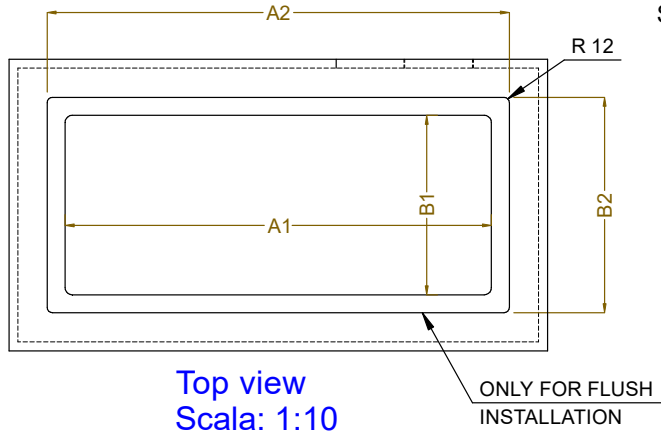
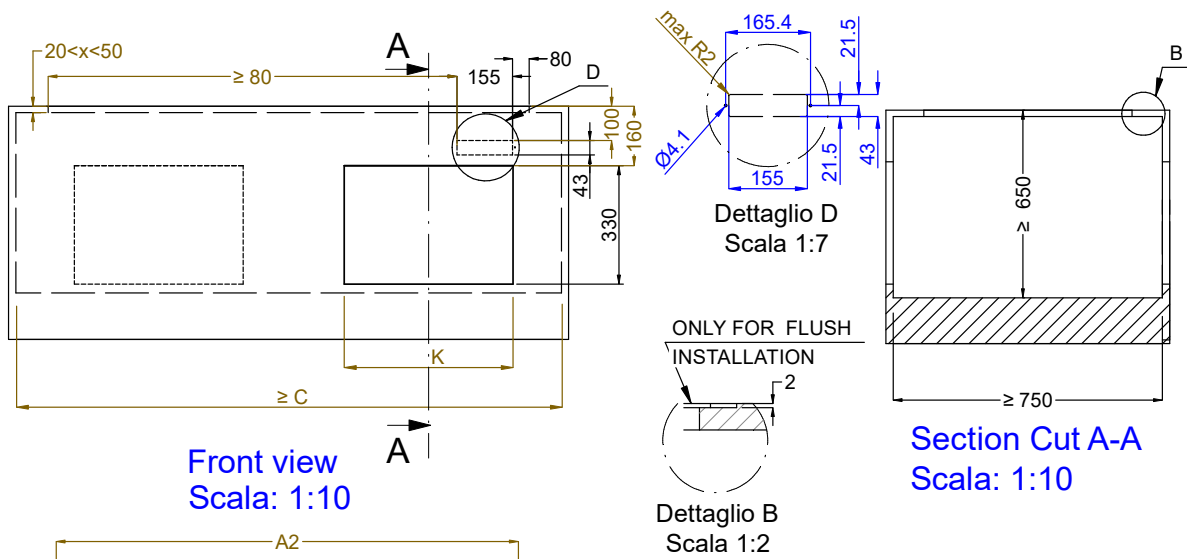

CAPACITY	CUTOUT		LOWERING FOR FLUSH INSTALLATION		C	K
	A1	B1	A2	B2		
2GN	740	580	774	624	870	470
3GN	1070		1104		1200	
4GN	1390		1424		1520	

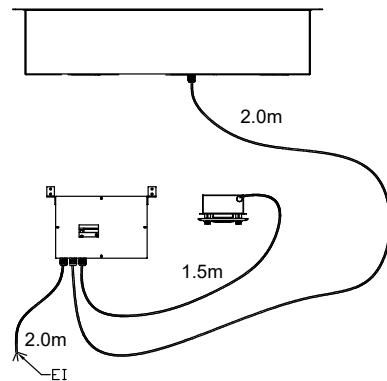
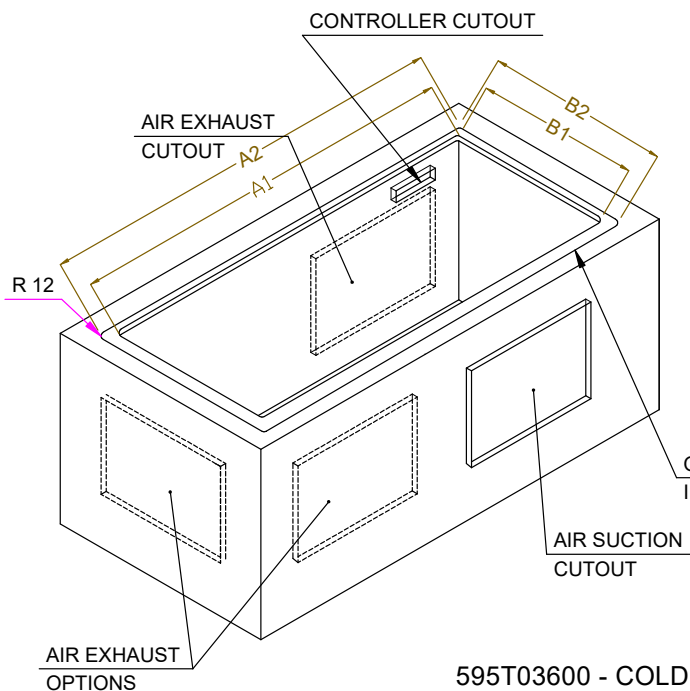

ONLY FOR FLUSH INSTALLATION

595T03600 - COLD S/S SURFACE OVERSH. ON THE FRAME